

Please check the examination details below before entering your candidate information

Candidate surname					Other names				
Centre Number				Candidate Number					

**Pearson Edexcel International GCSE**

Time 2 hours

Paper reference **4MA1/1F**

**Mathematics A**  
**PAPER 1F**  
**Foundation Tier**



**You must have:** Ruler graduated in centimetres and millimetres, protractor, pair of compasses, pen, HB pencil, eraser, calculator. Tracing paper may be used.

Total Marks

### Instructions

- Use **black** ink or ball-point pen.
- **Fill in the boxes** at the top of this page with your name, centre number and candidate number.
- Answer **all** questions.
- Without sufficient working, correct answers may be awarded no marks.
- Answer the questions in the spaces provided  
– *there may be more space than you need.*
- **Calculators may be used.**
- You must **NOT** write anything on the formulae page.  
Anything you write on the formulae page will gain **NO** credit.

### Information

- The total mark for this paper is 100.
- The marks for **each** question are shown in brackets  
– *use this as a guide as to how much time to spend on each question.*

### Advice

- Read each question carefully before you start to answer it.
- Check your answers if you have time at the end.

Turn over ►

P72435A

©2023 Pearson Education Ltd.

J:1/1/1/1/1/



  
Pearson

**International GCSE Mathematics**  
**Formulae sheet – Foundation Tier**

**Area of trapezium** =  $\frac{1}{2}(a + b)h$

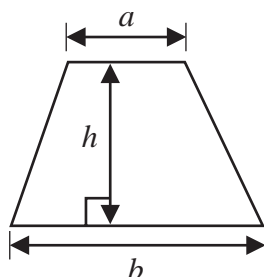

**Volume of prism** = area of cross section  $\times$  length

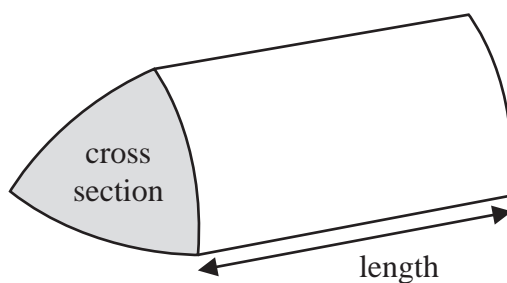

**Volume of cylinder** =  $\pi r^2 h$

**Curved surface area of cylinder** =  $2\pi r h$

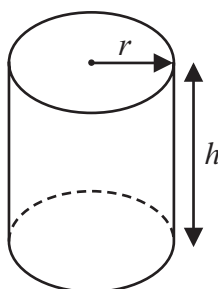

DO NOT WRITE IN THIS AREA

DO NOT WRITE IN THIS AREA

DO NOT WRITE IN THIS AREA



Answer ALL TWENTY FIVE questions.

Write your answers in the spaces provided.

You must write down all the stages in your working.

- 1 The table gives information about six plays written by William Shakespeare.

Play	Number of words	Year written
The Taming of the Shrew	21 055	1592
Henry V	26 119	1599
Hamlet	30 557	1602
Macbeth	17 121	1606
Julius Caesar	19 703	1599
King John	20 772	1596

- (a) Which of these six plays has the greatest number of words?

Hamlet (1)

(1)

Two of these six plays were written in the same year.

- (b) Write down the name of each of these plays.

Henry V

and

Julius Caesar (1)

(1)

The play Othello has 9329 more words in it than the play Macbeth.

- (c) Work out the number of words in the play Othello.

$$17121 + 9329 = 26450$$

26450 (1)

(1)

- (d) Write the number 21 055 in words.

Twenty one thousand and fifty five (1)

(1)

(Total for Question 1 is 4 marks)

DO NOT WRITE IN THIS AREA

DO NOT WRITE IN THIS AREA

DO NOT WRITE IN THIS AREA



- 2 Luca has 5 kg of chopped tomatoes.  
He also has some empty tins.

When full, each tin holds 350 g of chopped tomatoes.

Luca fills as many tins as possible with the chopped tomatoes.

Work out the weight of the chopped tomatoes remaining after Luca has filled as many tins as possible.

Give the units of your answer.

$$5 \text{ kg} \times 1000 = 5000 \text{ g} \quad (1)$$

$$\frac{5000}{350} = 14.2857 \dots$$
$$\approx 14 \quad (1)$$

$$350 \text{ g} \times 14 = 4900 \text{ g} \quad (1)$$

$$5000 \text{ g} - 4900 \text{ g} = 100 \text{ g} \quad (1)$$

100 g

(Total for Question 2 is 4 marks)



DO NOT WRITE IN THIS AREA

DO NOT WRITE IN THIS AREA

DO NOT WRITE IN THIS AREA

3 A sequence of patterns is made from squares.

**Pattern number 1**



**Pattern number 2**



**Pattern number 3**

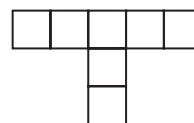

(a) In the space below, draw Pattern number 4

**Pattern number 4**

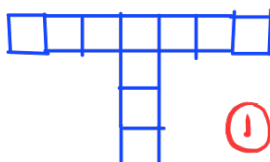

(1)

(b) Complete the table.

<b>Pattern number</b>	1	2	3	4	5
<b>Number of squares</b>	1	4	7	10	13

(1)

(1)

(c) Work out the number of squares in Pattern number 8

6      7      8  
16    19    22

22

(1)

(1)

Angus says

“there are 42 squares in Pattern number 15”

Angus is incorrect.

(d) Explain why.

$3 \times 15 - 2 = 43$  (1)

(1)

(Total for Question 3 is 4 marks)



4 (a) Write 0.8 as a percentage.

80 (1) %  
(1)

(b) Write down the value of the 3 in the number 4.7634

thousandth (1)  
(1)

(c) Write these decimals in order of size.  
Start with the smallest decimal.

0.204      0.24      0.04      0.2      0.042

0.04, 0.042, 0.2, 0.204, 0.24 (1)

(1)

(d) Write 25.78621 correct to 2 decimal places.

25.79 (1)  
(1)

(e) Find the square root of 1296

$$\sqrt{1296} = 36$$

36 (1)  
(1)

(Total for Question 4 is 5 marks)

DO NOT WRITE IN THIS AREA

DO NOT WRITE IN THIS AREA

DO NOT WRITE IN THIS AREA



DO NOT WRITE IN THIS AREA

DO NOT WRITE IN THIS AREA

DO NOT WRITE IN THIS AREA

5 Adam has 8 packets of noodles.  
Here is the flavour of noodles in each packet.

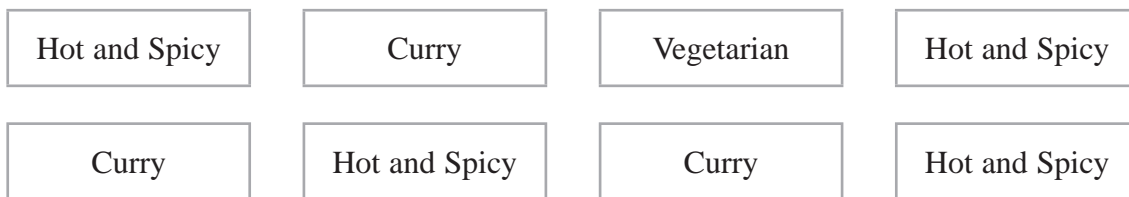

Adam takes at random a packet of noodles.

(a) (i) On the probability scale, mark with a cross (×) the probability that Adam takes a packet of Hot and Spicy noodles.

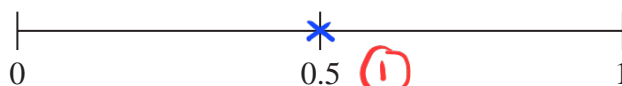

(1)

(ii) Circle the word that best describes the likelihood that Adam takes a packet of Vegetarian noodles.

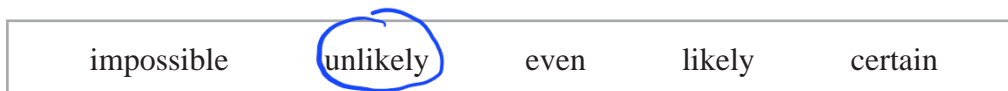

(1)

Belinda asks 20 people to name the type of rice that they each like the best.

Here are her results.

arborio	jasmine	basmati	jasmine	basmati
basmati	arborio	wild	jasmine	jasmine
jasmine	jasmine	arborio	basmati	basmati
wild	basmati	jasmine	wild	arborio

(b) Complete the frequency table for Belinda's results.

Type of rice	Tally	Frequency
arborio		4
basmati		6 <span style="border: 1px solid red; border-radius: 50%; padding: 2px;">2</span>
jasmine		7
wild		3

(2)

(Total for Question 5 is 4 marks)



- 6 Sandeep sells 600 tickets for an event.  
He receives a total of \$7200 from selling the tickets.

$\frac{1}{4}$  of the tickets sold are child tickets.

The rest of the tickets sold are adult tickets.

The cost of an adult ticket is \$13.60

Work out the cost of a child ticket.

$$\text{child: } \frac{1}{4} \times 600 = 150 \quad (1)$$

$$\text{Adult: } 600 - 150 = 450$$

$$450 \times 13.60 = 6120 \quad (1)$$

$$\frac{7200 - 6120}{150} = \frac{1080}{150} \quad (1)$$

$$= 7.20 \quad (1)$$

\$ ..... 7.20

(Total for Question 6 is 4 marks)





7 (a) Simplify  $5p \times 9k$

$$5 \times 9 \times p \times k$$

$$= 45pk$$

$$45pk \quad (1)$$

(1)

(b) Simplify  $3e + 2f + 8e - 7f$

$$3e + 8e + 2f - 7f$$

$$= 11e - 5f \quad (2)$$

$$11e - 5f$$

(2)

(c) Solve  $2d + 7 = 16$

$$2d = 9$$

$$d = \frac{9}{2} \quad (1)$$

$$d = 4.5 \quad (1)$$

$$d = 4.5$$

(2)

(Total for Question 7 is 5 marks)

DO NOT WRITE IN THIS AREA

DO NOT WRITE IN THIS AREA

DO NOT WRITE IN THIS AREA



P 7 2 4 3 5 A 0 9 2 8

8 Here is a scale drawing showing the positions of Paris and Bordeaux.

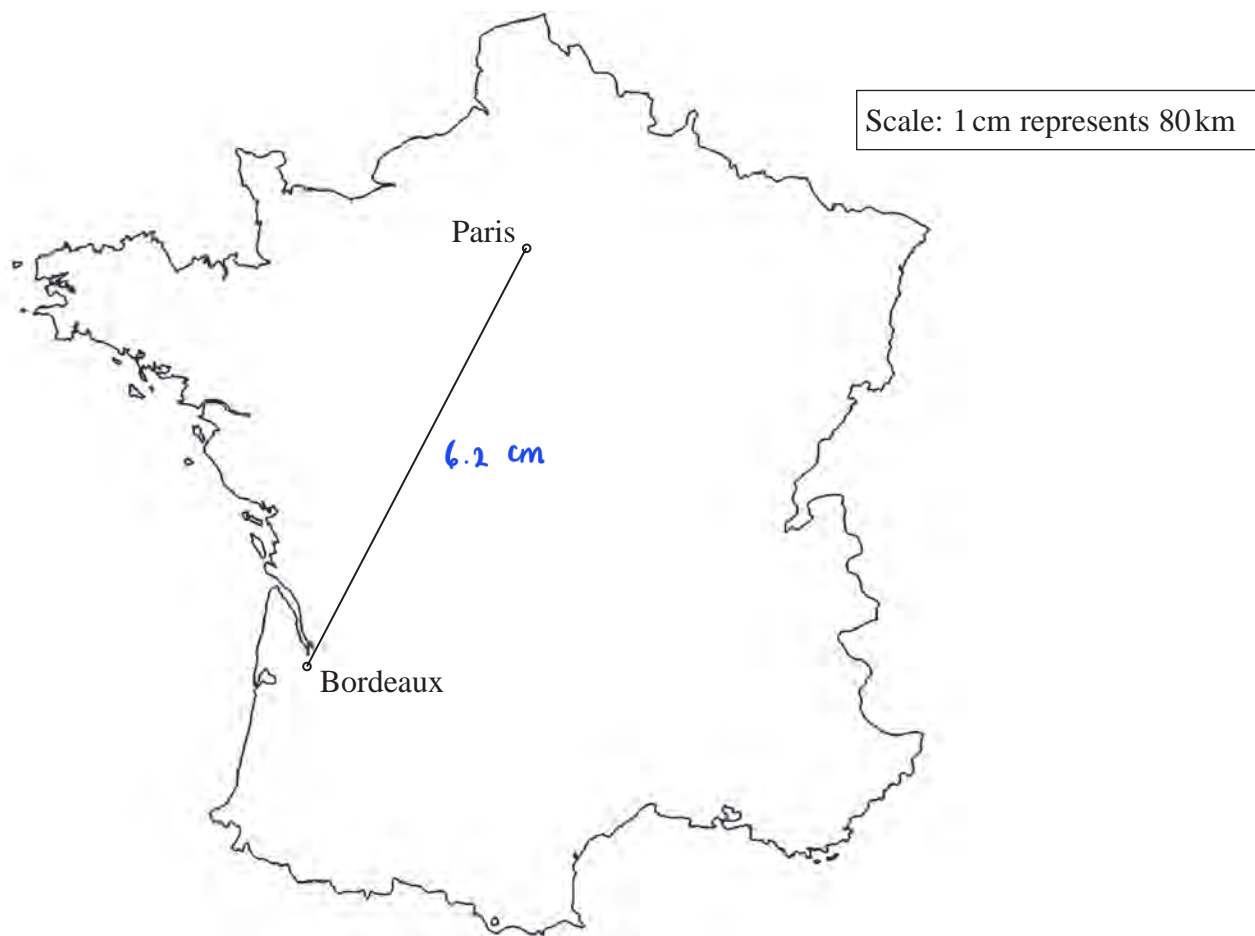

Alain drives from Paris to Bordeaux.  
The distance that he drives is 590 km.

This distance is greater than the actual straight line distance between Paris and Bordeaux.

How much greater?  
Show your working clearly.

$$6.2 \times 80 = 496 \quad (1)$$

(1)

$$590 - 496 = 94 \quad (1)$$

(1)

94

..... km

(Total for Question 8 is 4 marks)



9 Avner has two fair spinners.

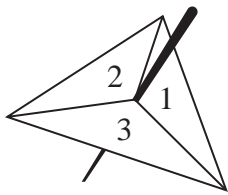

Spinner A

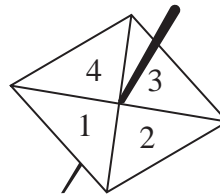

Spinner B

Spinner A can land on 1, 2 or 3  
 Spinner B can land on 1, 2, 3 or 4

Avner **multiplies** the number on which spinner A lands by the number on which spinner B lands to find his score.

- (a) Complete the table to show all possible scores.  
 Seven of the scores have been completed for you.

		Spinner A		
		1	2	3
Spinner B	1	1	2	3
	2	2	4	6
	3	3	6	9
	4	4	8	12

(2)

(2)

Avner spins spinner A once and spinner B once.

- (b) Find the probability that his score is an odd number.

$$\frac{4}{12} \text{ (1)}$$

(1)

(Total for Question 9 is 3 marks)

DO NOT WRITE IN THIS AREA

DO NOT WRITE IN THIS AREA

DO NOT WRITE IN THIS AREA



10 Orange squash is made from orange juice and water.

Sean has two different cartons of orange squash, carton **P** and carton **Q**.  
The table gives information about the two cartons.

Carton P	Carton Q
Total volume of orange squash is 250 millilitres	Total volume of orange squash is 250 millilitres
30% of the total volume is <b>orange juice</b> and the remainder is water	160 millilitres of the total volume is <b>water</b> and the remainder is orange juice

Work out the difference in the volume of orange juice in carton **P** and the volume of orange juice in carton **Q**.

$$P: \frac{30}{100} \times 250 = 75 \quad (1)$$

$$Q: 250 - 160 = 90$$

$$90 - 75 = 15 \quad (1)$$

..... millilitres

(Total for Question 10 is 3 marks)

DO NOT WRITE IN THIS AREA

DO NOT WRITE IN THIS AREA

DO NOT WRITE IN THIS AREA



11 On the grid below, draw the graph of  $y = 1 - 2x$  for values of  $x$  from  $-2$  to  $3$

$x$	-2	-1	0	1	2	3
$y$	5	3	1	-1	-3	-5

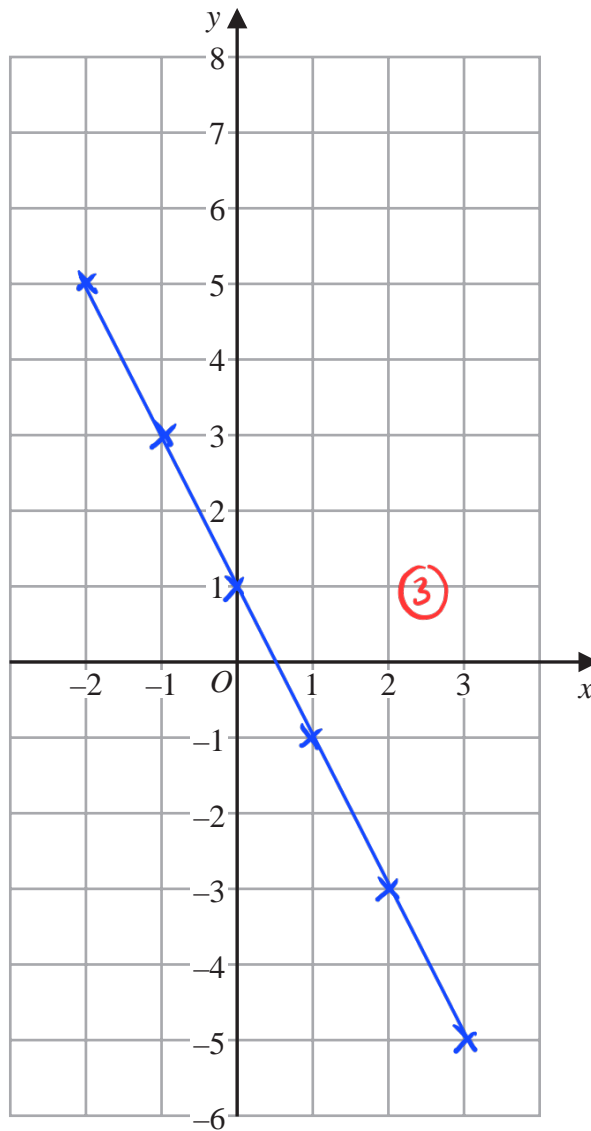

(Total for Question 11 is 3 marks)



12 (a) Show that  $\frac{7 \times 3}{8 \times 3} - \frac{5 \times 2}{12 \times 2} = \frac{11}{24}$

$$\frac{21}{24} - \frac{10}{24} \quad (1)$$

$$= \frac{11}{24} \quad (1)$$

(2)

- (b) Find the highest common factor (HCF) of 130 and 208  
Show your working clearly.

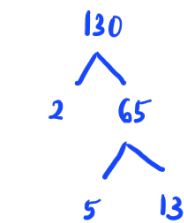

$$2 \times 5 \times 13$$

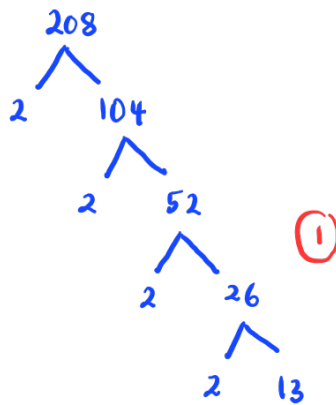

$$2^4 \times 13$$

$$\text{HCF} = 2 \times 13 = 26 \quad (1)$$

26

(2)

(Total for Question 12 is 4 marks)



$$13 \quad p = t - ac$$

$$t = 18$$

$$a = -3$$

$$c = 5$$

(a) Work out the value of  $p$

$$p = 18 - (-3)(5) \quad (1)$$

$$= 18 + 15$$

$$= 33 \quad (1)$$

$$p = \frac{33}{1} \quad (2)$$

(b) Make  $x$  the subject of the formula  $d = 3x + 10$

$$3x = d - 10 \quad (1)$$

$$x = \frac{d - 10}{3} \quad (1)$$

$$x = \frac{d - 10}{3}$$

(2)

(Total for Question 13 is 4 marks)

DO NOT WRITE IN THIS AREA

DO NOT WRITE IN THIS AREA

DO NOT WRITE IN THIS AREA



14

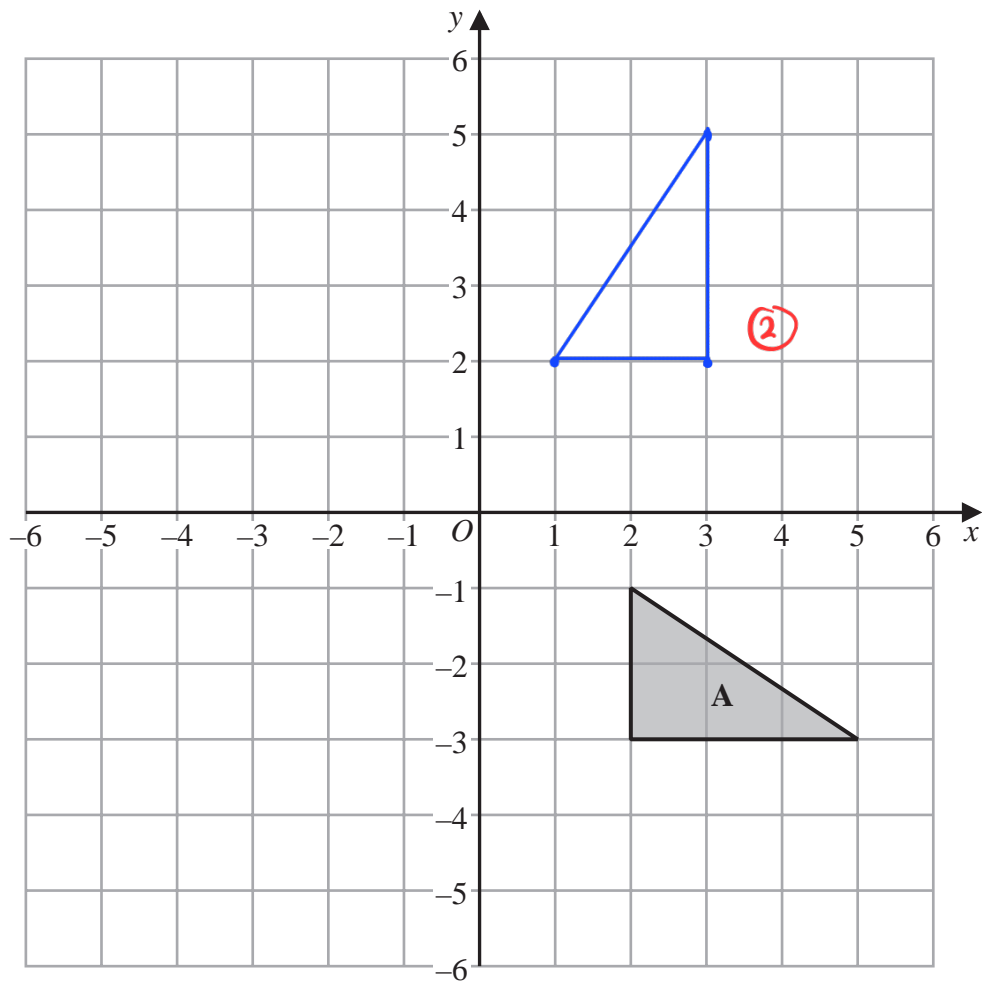

DO NOT WRITE IN THIS AREA

DO NOT WRITE IN THIS AREA

DO NOT WRITE IN THIS AREA

(a) On the grid, rotate triangle **A**  $90^\circ$  anticlockwise about centre *O*

(2)





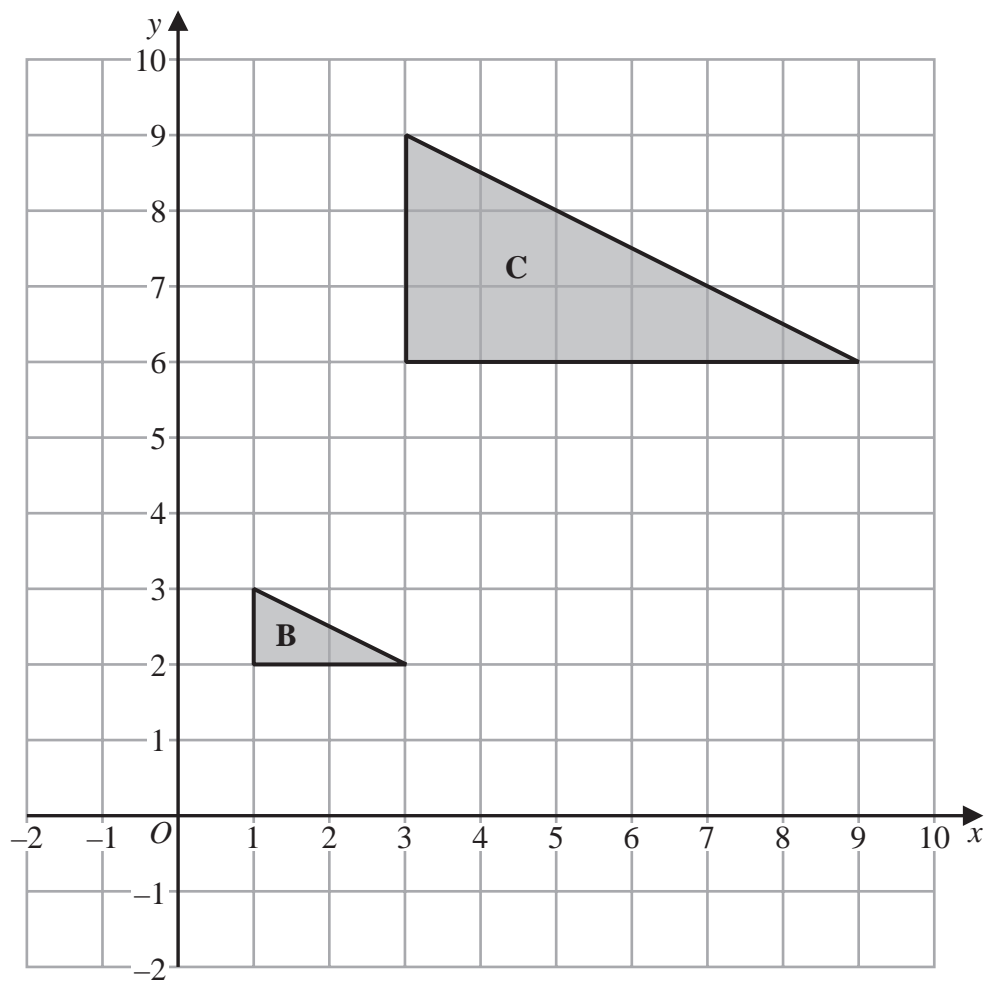

(b) Describe fully the single transformation that maps triangle **B** onto triangle **C**

Enlargement of scale factor 3 at point (0,0) .

②

(2)

(Total for Question 14 is 4 marks)

DO NOT WRITE IN THIS AREA

DO NOT WRITE IN THIS AREA

DO NOT WRITE IN THIS AREA



P 7 2 4 3 5 A 0 1 7 2 8

- 15 Here is a floor plan of a stage.  
The plan is formed from a triangle and a rectangle.

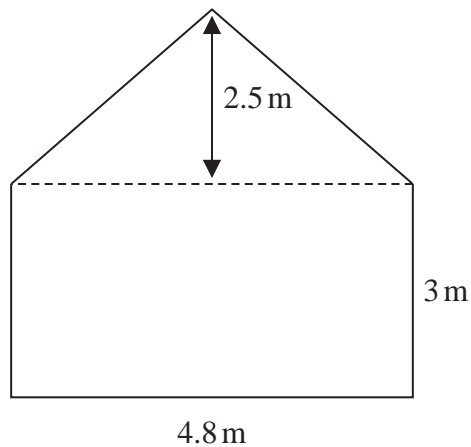

Diagram NOT  
accurately drawn

The stage manager is going to paint the floor.

One tin of paint covers an area of  $1.8 \text{ m}^2$

One tin of paint costs \$16.40

Paint can only be bought in full tins.

The stage manager has \$190 to spend.

Does the stage manager have enough money to buy enough tins to paint all of the floor?

Show your working clearly.

$$\text{Area triangle} = \frac{1}{2} \times 4.8 \times 2.5 = 6 \quad (1)$$

$$\text{Area rectangle} = 4.8 \times 3 = 14.4 \quad (1)$$

$$\text{Total area} = 6 + 14.4 = 20.4$$

$$\frac{20.4}{1.8} = 11.3 \dots \quad (1)$$

$\approx 12$  tins are needed

$$12 \times 16.40 = 196.80 \quad (1)$$

$$\text{No. } 196.80 > 190.$$

(1)

(Total for Question 15 is 5 marks)

DO NOT WRITE IN THIS AREA

DO NOT WRITE IN THIS AREA

DO NOT WRITE IN THIS AREA



16 80 students entered a dancing competition.

The table gives information about the length of time, in minutes, for which each student spent dancing.

Time ( $m$ )	Frequency
$0 < m \leq 12$	11
$12 < m \leq 24$	25
$24 < m \leq 36$	23
$36 < m \leq 48$	15
$48 < m \leq 60$	6

Work out an estimate for the mean length of time the students spent dancing.

$$\text{Mean} = \frac{(6 \times 11) + (18 \times 25) + (30 \times 23) + (42 \times 15) + (54 \times 6)}{80} \quad (1)$$

$$= \frac{66 + 450 + 690 + 630 + 324}{80} \quad (1)$$

$$= \frac{2160}{80} \quad (1)$$

$$= 27 \quad (1)$$

27

..... minutes

(Total for Question 16 is 4 marks)



- 17 Solve  $3(2 - 4x) = 5 - 8x$   
Show clear algebraic working.

$$6 - 12x = 5 - 8x \quad (1)$$

$$6 - 5 = -8x + 12x \quad (1)$$

$$1 = 4x$$

$$x = \frac{1}{4} \quad (1)$$

$$x = \frac{1}{4}$$

(Total for Question 17 is 3 marks)

DO NOT WRITE IN THIS AREA

DO NOT WRITE IN THIS AREA

DO NOT WRITE IN THIS AREA



- 18 Use ruler and compasses only to construct the perpendicular bisector of line  $AB$   
You must show all your construction lines.

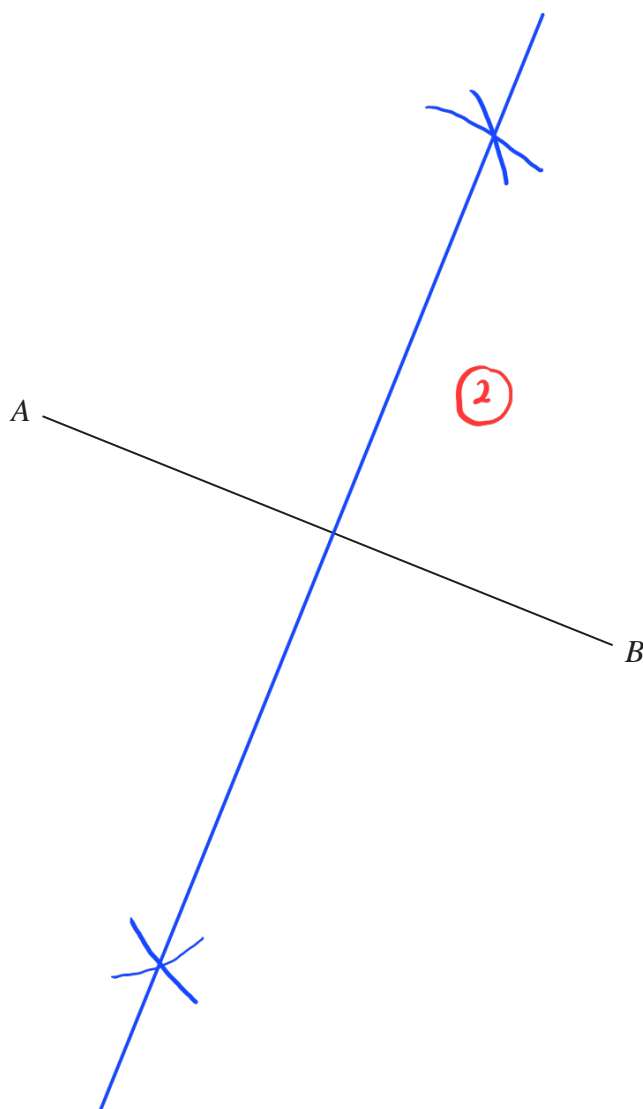

(Total for Question 18 is 2 marks)



19 The diagram shows a pentagon.

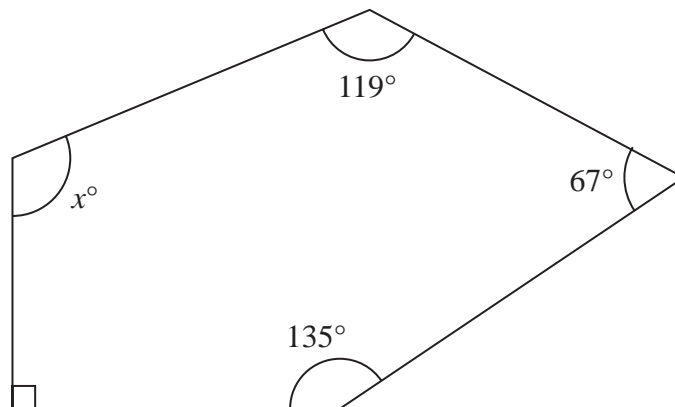

Diagram **NOT** accurately drawn

Work out the value of  $x$

$$\text{Total angle : } 3 \times 180^\circ = 540^\circ \quad (1)$$

$$540 - 90 - 135 - 67 - 119 \quad (1)$$

$$= 540 - 411$$

$$= 129 \quad (1)$$

$$x = \dots\dots\dots 129$$

(Total for Question 19 is 3 marks)

DO NOT WRITE IN THIS AREA

DO NOT WRITE IN THIS AREA

DO NOT WRITE IN THIS AREA



20 In a box, there are only green sweets, orange sweets and yellow sweets.

There are 280 sweets in the box so that

the number of green sweets : the number of orange sweets = 2 : 3

and

the number of orange sweets : the number of yellow sweets = 1 : 5

Work out how many green sweets there are in the box.

$$G : O : Y$$

$$2 \quad 3$$

$$1 \times 3 \quad 5 \times 3$$

$$2 : 3 : 15 \quad (1)$$

$$\frac{2}{2+3+15} \times 280$$

$$= \frac{2}{20} \times \cancel{280}^{14} \quad (1)$$

$$= 28 \quad (1)$$

28

(Total for Question 20 is 3 marks)



21 Shane bought a car.

The amount Shane paid for the car was \$32 000

Theresa also bought a car.

To pay for this car, Theresa paid a deposit of \$18 000 together with 14 monthly payments of \$1160

Theresa paid more for her car than Shane paid for his car.

(a) Work out how much more Theresa paid as a percentage of the amount Shane paid.

$$18\,000 + 14(1160)$$

$$= 18\,000 + 16\,240$$

$$= 34\,240 \quad (1)$$

$$34\,240 - 32\,000 = 2\,240 \quad (1)$$

$$\frac{2\,240}{32\,000} \times 100 = 7 \quad (1)$$

$$\frac{7}{(4)} \%$$

Kylie bought a van.

After 1 year, the value of the van was \$39 865

During this year, the value of the van decreased by 15%

(b) Work out the value of the van when Kylie bought it.

$$100 - 15 = 85 \quad (1)$$

$$\frac{85}{100} \times \text{initial} = 39\,865$$

$$\text{initial} = 39\,865 \times \frac{100}{85} \quad (1)$$

$$= 46\,900 \quad (1)$$

$$\$ \frac{46\,900}{(3)}$$

(Total for Question 21 is 7 marks)

DO NOT WRITE IN THIS AREA

DO NOT WRITE IN THIS AREA

DO NOT WRITE IN THIS AREA





- 22 Some members of a library were asked to name the type of book that they each liked to read the best.

One of the members is chosen at random.

The table shows information about the probability of the type of book that this member answered.

Type of book	comedy	romance	mystery	thriller
Probability	0.24	0.40	$3x$	$x$

48 members answered comedy books.

Work out how many of the members answered mystery books.

$$1 - 0.24 - 0.40 = 0.36 \quad (1)$$

$$4x = 0.36$$

$$x = 0.09 \quad (1)$$

$$\frac{48}{0.24} = 200$$

$$3(0.09) \times 200$$

$$0.27 \times 200 \quad (1)$$

$$= 54 \quad (1)$$

54

(Total for Question 22 is 4 marks)



23 The diagram shows a triangle  $ABC$  inside a semicircle.

Diagram **NOT**  
accurately drawn

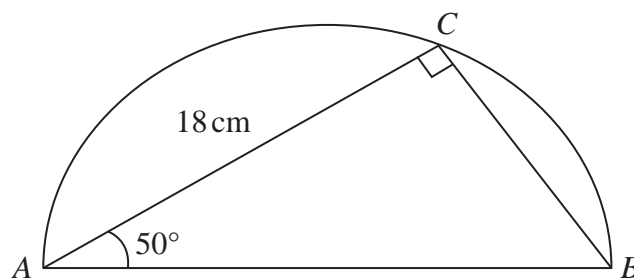

$A$ ,  $B$  and  $C$  are points on the semicircle.

$AB$  is the diameter of the semicircle.

Angle  $ACB = 90^\circ$

Angle  $BAC = 50^\circ$

$AC = 18$  cm

Work out the perimeter of the semicircle.

Give your answer correct to 2 significant figures.

$$\cos 50^\circ = \frac{18}{AB} \quad (1)$$

$$AB = \frac{18}{\cos 50^\circ} \quad (1)$$

$$= 28.0030 \dots$$

$$\frac{1}{2} \times \pi \times 28.0030 \dots = 43.9 \dots \quad (1)$$

$$28.0030 \dots + 43.9 \dots \quad (1)$$

$$= 71.9900 \dots$$

$$\approx 72 \quad (1)$$

DO NOT WRITE IN THIS AREA

DO NOT WRITE IN THIS AREA

DO NOT WRITE IN THIS AREA



DO NOT WRITE IN THIS AREA

DO NOT WRITE IN THIS AREA

DO NOT WRITE IN THIS AREA

72

..... cm

(Total for Question 23 is 5 marks)

24 (a) Write  $6.25 \times 10^{-4}$  as an ordinary number.

0.000625 (1)

(1)

(b) Work out  $(2.4 \times 10^{12}) \div (9.6 \times 10^4)$   
Give your answer in standard form.

$$\frac{2.4}{9.6} \times 10^{12-4}$$

$$= 0.25 \times 10^8 \quad (1)$$

$$= 2.5 \times 10^7 \quad (1)$$

2.5 × 10<sup>7</sup>

(2)

(Total for Question 24 is 3 marks)



P 7 2 4 3 5 A 0 2 7 2 8

25 (a) Factorise  $y^2 - 2y - 48$

$$(y+6)(y-8)$$

$$\frac{(y+6)(y-8)}{(2)}$$

(b) Write down the inequality shown on the number line

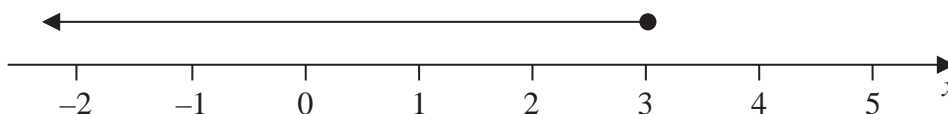

$$x \leq 3 \quad (1)$$

(c) Solve the inequality  $7w + 6 > 12w + 14$

$$7w - 12w > 14 - 6 \quad (1)$$

$$-5w > 8 \quad (1)$$

$$w < -\frac{8}{5} \quad (1)$$

$$w < -\frac{8}{5} \quad (3)$$

(Total for Question 25 is 6 marks)

TOTAL FOR PAPER IS 100 MARKS

